

Amazfit Smartwatch User Manual

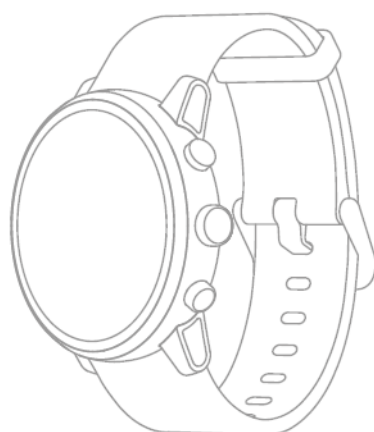

Contents

Watch Operating Instructions & Watch Status	3
1. Button Descriptions.....	3
2. Touch Screen Gesture Operations.....	3
3. Off-Screen Mode	4
4. Low-Light Mode	4
5. Lock-Screen Second-Hand Mode	5
6. System Status Symbol.....	5
Wearing the Watch & Charging Methods	6
1. Daily Wear	6
2. Wear during exercise	6
3. Charging	7
Use of Watch Functions	7
1. Watch Face.....	7
2. Widgets & Applications	7
3. Exercise.....	8
4. Health	11
5. Heart Rate	11
6. Playing Music.....	12
7. Mobile Phone Music Control	13
8. Sleep	13
9. Bluetooth Phone	13
10. Weather	14
11. Alarms	14
12. Stopwatch.....	14
13. Timer	14
14. Compass	14
15. Schedule.....	15
Watch Notifications.....	15
1. Message Notifications.....	15
Connecting to a Computer	16
1. Connecting with a PC	16
2. Connecting with a Mac.....	16
3. Copying Files.....	17
Upgrading the Watch System.....	17
Daily Watch Maintenance	17

Watch Operating Instructions & Watch Status

1. Button Descriptions



Watch Status	Button Functions	Tapping Methods
In standby	Unlock the watch	Short press
After unlocking	Initiate the voice function from the watch face	Short press
	Return to the watch face from other interface	Short press
Others	Turn on the watch	Press and hold for 2 seconds
	Turn off the watch	Press and hold for 6 seconds

2. Touch Screen Gesture Operations

Tap the screen function items	Use this feature to go to the next item or select the current item
Slide the screen left and right	Switch the interface to landscape mode
Swipe the screen up and down	Scroll up and down the interface
Long press the watch-face interface	Activate the watch-face selection function

3. Off-Screen Mode

After binding the watch to your phone, it enters the off-screen mode by default. In this mode, the watch displays a black screen in standby, and will not be display the time and the watch face until you raise your wrist. When a message notification is received, the watch screen will light up to display the message content. Turning on the off-screen mode will extend the watch's standby time.

You can switch from the off-screen mode to **Low-Light Mode** in **System Settings > Preferences > Lock Screen Mode** in the watch.

4. Low-Light Mode



In the **low-light mode**, only the time is displayed on the screen in the standby state (the pointer and the digital time are respectively displayed for the pointer watch face and the digital watch face). The entire watch face will not be displayed until you raise your wrist. When a message notification is received, the watch screen will light up to display the message content.

Turning on the low-light mode will reduce the standby time on the watch.

You can switch back to the **off-screen mode** in the **System Settings > Preferences > Lock Screen Mode** in the watch.



5. Lock-Screen Second-Hand Mode

When the lock-screen second-hand mode is turned on, the second hand or second is displayed on the watch face under the **black-screen mode** when you raise your wrist, while in the **low-light mode** the second hand or second is displayed in the standby state and when you raise your wrist.

The lock-screen second-hand mode is turned off by default, which reduces the watch's standby time when turned on.

You can turn it on or off in **System Settings > Preferences > Watch Face > Lock-Screen Second-Hand Mode** in the watch.

6. System Status Symbol

Once your watch is unlocked, the watch face will display system status symbols, each of which represents a different status.

[Charging]	In the charging state.
[Fully charged]	In a fully charged state.
[Low Battery Protection Mode]	In a low-battery protection state. When the watch power is 5% or below, it will enter the low-battery protection mode. At this time, the watch must be charged more than 5% before exiting the protection mode.
[Disconnected from mobile phone]	The watch is disconnected from the mobile phone. When the watch is too far away from the phone to disconnect the Bluetooth connection or Bluetooth broadcasting is turned off on the phone while the flight mode is enabled on the watch, the watch-face interface will display this symbol.

[Zen mode]	Zen mode is turned on. When this mode is turned on, the watch will not automatically display and vibrate after receiving a message, call, etc.
[Flight mode]	Flight mode is turned on. When the flight mode is turned on, the watch will turn off the Bluetooth and Wi-Fi connection. In this mode, the watch will be disconnected from the mobile phone.
[Headset connection]	The watch is connected to a Bluetooth headset. This will increase system power consumption.
[Play music]	The watch is playing music. If the watch is not connected to a Bluetooth headset, the music will be played via the speakers that come with the watch.

Wearing the Watch & Charging Methods

1. Daily Wear

To ensure that the optical heart-rate monitor detects the data properly, we recommend wearing the watch with two fingers' width below your wrist bone, making sure it's fairly snug against your skin.



2. Wear during exercise

When running or doing other activities, it is recommended that you wear your watch with a tight fit that is comfortable and does not slide up or down your wrist. The watch band shouldn't be too tight, nor should it be allowed to shake freely.

3. Charging

Connect the watch to the charging dock and then attach the other end of USB cable to the USB power adapter. Then, the charging status will be displayed on the watch. Note that the direction of the charging contact on the dock should be consistent with the direction of the metal contacts on the watch during the connection. Once insertion is made, the watch will not loosen out of the dock.

The watch will automatically turn off the display when charging, and tap the screen to display the charging progress interface.

Charging requirements: It is recommended that you use the USB port on your computer or a branded mobile phone charger for charging. The rated input voltage of the mobile phone charger must be DC 5.0v, and the input current must be greater than 500mA.

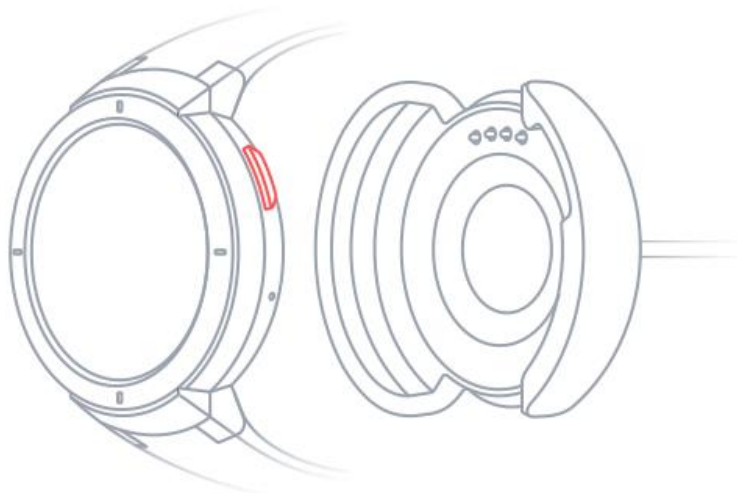

Use of Watch Functions

1. Watch Face

Changing Watch Faces

When the watch-face interface is pressed and held, the watch-face selection interface will appear, displaying the current system's built-in and installed watch faces.

You can also change the watch face in the "Amazfit Watch App" > "Profile" > "My Watch" > "Watch Face Store" on your phone.

2. Widgets & Applications

Applications refer to the specific function on the watch which can be used independently such as sleep, heart rate, compass, etc.

Widgets refer to the application interface that is displayed on the right side of the watch face. It can display the status of the current application summary information.



Show or hide the widgets

"**Widgets and Application Management**" can be found in the "**My Watch**" interface of the Amazfit Watch app. It lets you choose whether to display widgets and change the displayed order of widgets and applications on the watch.

3. Exercise

Sports list



The original version of the watch features 11 sports modes, such as **running, walking, cycling, indoor running, climbing** and so on. More sports will be supported as the system version is updated.

Starting an Activity



After entering the preparation page for an outdoor activity such as running, the watch will automatically search for the GPS signal. Once the signal is obtained, tap GO to start running. After entering an indoor activity such as an elliptical trainer, tap GO to start the activity.

About GPS Search

When you enter the exercise preparation page for outdoor activities such as running, the watch will automatically start GPS positioning and alert you when positioning is successful. GPS positioning is automatically turned off when you leave the exercise preparation page or complete an activity.

The watch will search for a GPS signal continuously for 3 minutes. If this time elapses without successful positioning, it will ask you to reposition. After 20 minutes of inactivity, the watch will stop searching to conserve the battery. If you continue to use it, you need to re-search.

i. Tips for Positioning:

GPS positioning should be done in an open area in the outdoor. We recommend searching GPS before starting an activity. If you are in a crowd, raising your arm to your chest will accelerate the positioning.

ii. Assisted GPS (AGPS):

AGPS refers to a GPS satellite orbit information data that can help the watch to perform GPS positioning faster.

While keeping your watch connected to your phone's Bluetooth, the watch regularly synchronizes and updates AGPS data with the Amazfit Watch app on a daily basis. If watch hasn't sync with your Amazfit Watch app for 7 days, the AGPS data will expire. The positioning speed may be affected when AGPS expires, so the watch will remind you to update when you begin an activity.



Sports Setting

Swipe up from the exercise preparation page to display "Sports Setting." Tap to adjust the settings of the running items as needed.

i. Exercise Alert

Setting the exercise alerts enables you manage a variety of alerts, such as full-mile alerts, heart rate alerts, and more. It can be set as needed in the exercise settings.

ii. Auto Lap

You can set automatic lap miles in sports such as running, and you can turn on auto lap alerts. The watch will record the details of each lap, and you can view the info after you complete your activity.



iii. Peripheral Connection

The watch supports Bluetooth 4.0 heart-rate chest straps and A2DP Bluetooth headsets. The above devices can be paired or connected in the peripheral connection settings in "Sports Setting" for use during such activities.

The watch will connect just one of the same Bluetooth devices at the same time. When you start an activity, the watch will actively try to connect to the most recently used device.

To connect the heart-rate chest strap:

- 1) First, wear the heart-rate chest strap on your body. (For users with dry skin, dip both sides of the strap in water.)
- 2) Find the heart-rate chest strap in the Watch - Sports Setting - External Device and pair and connect the strap.

Running Training

Interval Training

Open [Amazfit Watch App > Profile > My Watch](#) page, tap "Sports" under "App Settings" and select "Interval Training" to configure the interval workout that suits you best.

During exercise

i. Switching between the data screens

After you unlock your watch from standby mode by short pressing the button during exercise, you can switch between data screens by sliding horizontally. The leftmost screen is the "Sports" operation interface. Other screens are ones that contain data items and other sports charts.

ii. Switching between data items

You can configure the display of sports real-time data items in "Sports real-time data item settings" by clicking "Sports" in "App Settings" from the Amazfit Watch app [> Profile > My Watch](#) page.

iii. Pausing an Activity

Press a physical button in the unlock state to pause an activity and press it once again to resume. Or slide to the leftmost interface, or tap the Pause button on the interface to control the activity.

iv. Stopping an Activity

After an activity is paused, select "Save" to end the activity. Select "Resume" to continue and select "Discard" to not to save the current activity. After the end of the activity, the watch will show you and save the details of the current activity, you can check it again in the watch or the [Amazfit Watch app](#).

To check on the watch: Watch - Sports Record - Check all the sports data.

To check sports records on the [Amazfit Watch app](#): Amazfit Watch App - Sports - All sports

Checking Activities History

i. Checking on the Watch



4. Health

The number of steps, calories burning data, and cumulative activity statistics generated by the watch worn every day are aggregated into the Health app. Weekly report for the previous week will also be generated at 9:00 a.m. on Mondays to make it easier for you to view and track the your sports and health data weekly.

Note: Cumulative number of floors climbed refers to the number of floors that you climb per day. "One floor" is equivalent to an elevation of 3 meters.

5. Heart Rate

There are two modes of heart-rate measurement for the Amazfit Smartwatch, namely "[Single Measurement](#)" mode and "[All-day Heart Rate](#)" mode, which can be switched within the Heart Rate app.

Note: In order to improve the accuracy of the watch's heart-rate measurement, please wear your watch properly. Keep the area where the watch is worn clean and avoid the application of sunscreen.

[Single Measurement Mode](#)



You can take a manual heart-rate measurement when you need it. For more accurate heart-rate readings, please remain steady during the measurement.



All-day Heart Rate Mode

After the all-day heart rate mode is enabled, the Heart Rate app will display your heart rate per minute (bpm) as well as the average heart rate, maximum and minimum heart rate, and resting heart rate under the non-sports state during the day. (You need to wear the watch to sleep before you can get such assessments.)

To view the heart-rate value:

1. Click on the Heart Rate app on the watch to view the heart-rate value.
2. After opening the Heart Rate app to sync data, you can see the corresponding data on the Amazfit Watch app – [Status - Heart Rate](#) page.

Note: Turning on the all-day heart rate mode will reduce the watch's battery life.

6. Playing Music

Copying Music Files

The music player can play MP3 music files that were previously copied to the "Music" directory in the watch. Settings allow you to select the playback order of the music as well as the volume level while also supporting the volume adjustment of the Bluetooth headset and switching song control.

To copy songs: connect the watch to your computer (Recommended Operating System: Windows 7/8/10) via the provided USB cable and charging dock. After finding the watch's hard drive on your computer, copy songs in Mp3 format from your watch to the Music folder in the watch directory.

Playing Music in the Watch

You can play audio directly on your watch. When playing with the watch, the music playback symbol will be displayed on the watch face.

Connecting to a Bluetooth Headset

The watch supports Bluetooth headsets which include A2DP. You can select "[Bluetooth Devices](#)" to scan the headsets in "[Connect](#)" in the "[More Settings](#)" on the watch. When the connection is completed for the first time, the watch automatically connects to the headset each time the headset is turned on.

To connect to a headset:

- a. First put the Bluetooth headset into pairing mode (typically, press and hold the Bluetooth headset power key for approximately 5 seconds, and the Bluetooth light flashes red and blue, indicating that the headset is in the pairing mode).
- b. Open the Watch Bluetooth Device page, search for the Bluetooth headset and tap "Connect."



7. Mobile Phone Music Control

When the phone and watch remain connected, you can control your phone's music playback through your watch, such as Playback, Pause, Next, etc. If you want to use this function, you need to enable the "Mobile Phone Music Control" function in "App Notification Settings" in "Profile" > "Settings" > "Notification Settings" in the Amazfit Watch app, then you can swipe up on the watch-face interface to show the music-control interface.

Note: This function is primarily available for music players that come with mobile phones, but it also accommodates various audio applications such as Pandora.

8. Sleep

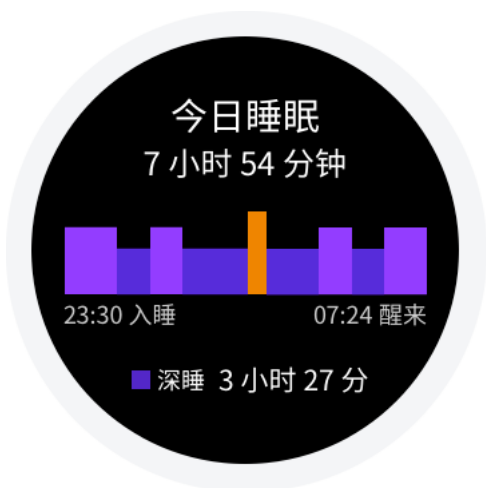

When you wear your watch to bed in the evening, it can automatically monitor your sleep and gives an analysis of data such as "sleeping time," "deep sleep" and "light sleep" after getting up the next day. Tap the **Sleep Tonight** interface to enter the list of **Sleep History**.

To check the sleep data:

1. You can tap the Sleep app on the watch to view;
2. Once the data is synchronized, you can view through **Amazfit Watch App > Status > Sleep**.

9. Bluetooth Phone

Note: Currently the Bluetooth phone feature is only available for Android phones. The Bluetooth connection between the watch and the phone must be maintained when making a call so that the phone can send and receive calls normally.

Use of Bluetooth Phone

Dialing a Bluetooth phone: Tap the Phone app on the watch, select the contact you want to make a call, or swipe to the phone-number entry interface and enter the desired number.

[\[Contact Interface\]](#) [\[Phone Dialing Interface\]](#)

Answering a Bluetooth phone: When the phone receives a call, there will be a corresponding call alert on the watch. If the phone is answered by clicking on the watch, the speaker and microphone that come with your watch will be used to answer the current call.

[\[Incoming Call Interface\]](#)

Bluetooth phone settings: Slide to the last page of the Phone app to set the call vibration, ringtone and other functions.

[\[Phone Settings\]](#)

10. Weather

The Weather widget lets you check weather information in recent days at any time. Weather data must be synchronized over the cellular network, so keep your watch connected with your mobile phone to update the weather in a timely manner.



Additionally, if a weather warning message is posted, the watch will also inform you immediately via the message.

11. Alarms

You can set up alarms on the watch. An alarm can be set to vibrate once or to repeat regularly. If you don't need the alarm you set up, you can remove it from the alarm list. Alarms remind you through vibration, you can choose to turn off or remind later (snooze). It will vibrate for five minutes and turn off automatically if you don't intervene.

12. Stopwatch

It lets you record lap times.

13. Timer

You can set a countdown timer, and it will vibrate when the time is up.

14. Compass

Your Amazfit Smartwatch will ask you to calibrate the built-in compass before using it for the first time. Tap the Compass interface to enter the information interface for altitude, latitude and longitude. The altitude and latitude/longitude information must be obtained in the outdoor open space via GPS signals. To avoid interference, stay away from magnetic fields during use.

15. Schedule

The schedule added on the smart page of the Amazfit Watch app will be displayed here. When the reminder time for the schedule is up, the watch will remind you via a message.

Watch Notifications



1. Message Notifications

When the watch is connected to the phone, the message of the phone can be displayed on the watch.

To enable app notifications: enable the specific notifications for Apps in "App Notification Settings" in "Profile" > "Settings" > "Notification Settings" from the Amazfit Watch app.

Note: If you bind your Android mobile phone to your watch, please white-list the Amazfit Watch app and give it permission for auto-start. Keep the app running in the background so that you can receive notifications. If the Amazfit Watch app is shut down in the background, your watch will disconnect from the app and you will no longer receive notifications.

Connecting to a Computer

1. Connecting with a PC



After connecting the watch to the charging dock and connecting it to the computer's USB, double-click on "Amazfit Smartwatch" in "My Computer" and then double-click "Internal Storage Device" to access the list of the files in the watch.

Note: Windows XP SP2 and below require installation of an MTP driver to connect the watch.

2. Connecting with a Mac



Android File Transfer

Your Mac computer needs to have the Android File Transfer tool installed in order for it to connect with your watch.

After connecting the watch to the dock and then to the computer's USB port, the Android File Transfer tool will automatically pop up and display a list of files in the watch.

3. Copying Files

When you access your watch through your computer, some folders will be displayed in the watch's root directory. You can copy the corresponding files into these folders.

/Music/	Stores MP3 files
/gpxdata/	Stores .gpx track files
/WatchFace/	Stores files imported externally

Upgrading the Watch System

Regular updating of the watch system facilitates continual optimization for top performance. Each upgrade will also fix recently discovered problems.

Note: Make sure your watch's battery stays above 40% before upgrading, and ensure that there is a stable Wi-Fi connection throughout the process to ensure that the upgrade goes smoothly.

Checking for updates on the watch

In [Watch - Settings - Check for updates](#), you can check if the current version of the watch is up to date.

Check for updates on the mobile phone apps

In the Amazfit Watch app you can check whether the watch system must be upgraded via [My Watch > More Watch Settings > Watch System Update](#).

Daily Watch Maintenance

Daily use

Do not rinse the watch body directly to avoid damage to components. Do not wear your watch in highly humid environments such as bathrooms, swimming pools and saunas.

Importer:
Beryko s.r.o.
Na Roudné 1162/76, 301 00 Plzeň
www.berko.cz